

Mediterrània S/105 Outdoor

Diseño / Design:
Alex Fernández Camps / 2019

Tipología: Suspensión
Typology: Pendant lamp

Ambiente: Exterior
Environment: Outdoor

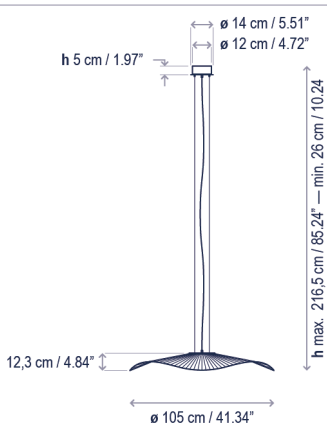

Descripción técnica / Technical description:

Peso Neto: 3,72 kg
Net Weight: 3,72 kg

1 Caja/Box | 117 x 117 x 31 cm | 0,42 m³
Peso bruto / Gross Weight: 10 kg

Materiales: Acero Inoxidable, Aluminio, Fibra de Polietileno Sintética.
Materials: Stainless Steel, Aluminum, Synthetic Polyethylene Fiber.

Opciones Dali/1-10v: consultar
Dali/1-10v options: consult

Difusor inferior: Policarbonato
Lower diffuser: Polycarbonate

Estructuras de metal acabadas con cataforesis y pintura de poliéster epoxi.
Metal surfaces coated with cataphoresis and epoxy polyester paint.

Pantallas tejidas a mano con fibra de polietileno sintética reciclable y no tóxica.
Hand woven with a recyclable and non-toxic synthetic polyethylene fiber.

Fuente de luz protegida por difusor de policarbonato.
Light source protected by polycarbonate diffuser.

Cable de neopreno negro resistente al agua.
Cable tensor acero inoxidable.
Black waterproof neoprene cable.
Stainless steel tensor cable.

Personalizable
Customizable

Certificaciones
Certifications



Descripción lámpara / Lamps description:

17,1 W LED / CRI: 90 / 2700K
2064 lm fuente de luz / light source

Ref	Acabados / Finishing	Ean13
33804214133	Regulable Triac Marrón - Fibra Sintética Marrón Dimmable Triac Brown - Brown Synthetic Fiber	8435493738819

Familia / Family: Mediterrània



bover
barcelona lights

Avda. Catalunya 173
Poligon Ind. Sud
08440 Cardedeu
Barcelona, Spain

T. +34 938 713 152
F. +34 938 462 089
info@bover.es
www.bover.es